

# XFL212R Miniature Load Cell



- 0-5 to 0-500N [0-1 to 100 lbf]
- Compression
- Extremely Flat 3,5 mm [0.14"]
- Diameter Only 12 mm [0.49"]
- Integrated Spherical Load Button
- For Static and Dynamic Applications

## DESCRIPTION

The **XFL212R** series is an extraordinarily thin miniature load cell with a temperature compensation module integrated into the output cable. This design allows Measurement Specialties, Inc. to manufacture extremely small sensors without sacrificing thermal zero and sensitivity performance. The **XFL212R** measures strain during compression in static and dynamic applications. Unlike sensors with flat force application surfaces, the **XFL212R** incorporates a spherical load button, which assures more precise loading and in return more accurate measurements.

The sensing element is fitted with a fully temperature compensated Wheatstone bridge equipped with high stability micro-machined silicon strain gages. The use of silicon strain gages optimizes its performance at low ranges and frequencies. The sensor is available in aluminum alloy or stainless steel, depending on the full scale range and can withstand considerable overloads.

With many years of experience as a designer and manufacturer of sensors, Measurement Specialties, Inc. often works with customers to design or customize sensors for specific uses and testing environments. To meet your needs we also offer complete turnkey systems. The matched components (sensor, power, amplifier and digital display) are formatted, calibrated and ready for immediate use.

## FEATURES

- Small size
- Flat sensor
- High Stiffness
- Integrated Spherical Load Button
- Other designs available on request

## APPLICATIONS

- Strain table measurement
- Micro component assembly tools
- Mechanical switches control
- Laboratory
- Robotic

## STANDARD RANGES

|                            |  |  |
|----------------------------|--|--|
| <b>F.S. Ranges in N</b>    | 5 - 10 - 20 - 50 - 100                 | 200 - 500                              |
| <b>F.S. Ranges in lbf</b>  | 1 - 2 - 4 - 10 - 20                    | 40 - 100                               |
| <b>Stiffness in N/m</b>    | $1.3 \times 10^5$ to $1.2 \times 10^8$ | $1.9 \times 10^8$ to $7.6 \times 10^8$ |
| <b>Stiffness in lbf/ft</b> | $8.9 \times 10^4$ to $8.2 \times 10^5$ | $1.3 \times 10^7$ to $5.2 \times 10^7$ |
| <b>Material</b>            | Aluminium                              | Stainless Steel                        |

# XFL212R Miniature Load Cell

## PERFORMANCE SPECIFICATIONS

All values are typical at temperature 20±1° C

| PARAMETERS                          |                                   |
|-------------------------------------|-----------------------------------|
| Operating Temperature Range (OTR)   | -40 to 120° C [-40 to 248° F]     |
| Compensated Temperature Range (CTR) | 0 to 60° C [32 to 140° F]         |
| Zero Shift in CTR                   | <2% F.S. / 50° C [100° F]         |
| Sensitivity Shift in CTR            | <2% of reading / 50° C [100° F]   |
| Range (F.S.)                        | 0-5 to 0-500 N [0-1 to 0-100 lbf] |
| Over-Range                          |                                   |
| Without Damage                      | 2 x F.S.                          |
| Without Destruction                 | 3 x F.S.                          |
| Accuracy                            |                                   |
| Linearity                           | ≤±1% F.S.                         |
| Hysteresis                          | ≤±1% F.S.                         |

### Electrical Characteristics

|                             |                |
|-----------------------------|----------------|
| <b>Model</b>                | <b>XFL212R</b> |
| Supply Voltage              | 10Vdc          |
| F.S. Output                 | 100 mV         |
| Zero Offset                 | <±10 mV        |
| Input Impedance/Consumption | 1000 to 3000Ω  |
| Output Impedance            | 500 to 1000Ω   |
| Insulation under 50Vdc      | ≥100MΩ         |

### Notes

1. Electrical Termination: Cable: Shielded cable with 4 wires (AWG36), standard length 2 m [6.5 ft] ; Compensation module at 1 m [3.25 ft] from transducer.
2. Material: Body in stainless steel or aluminum alloy
3. Protection Index: IP50
4. CE conformance according to EN 61010-1, EN 50081-1, EN 50082-1

# XFL212R Miniature Load Cell

## DIMENSIONS & WIRING SCHEMATIC (IN METRIC AND IMPERIAL)

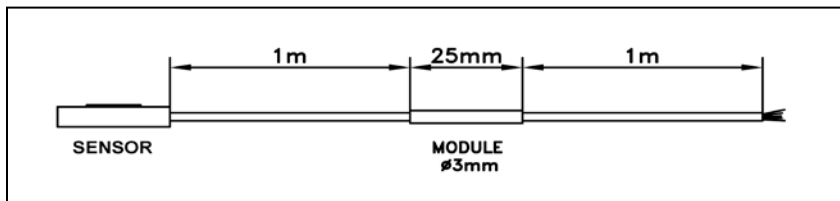
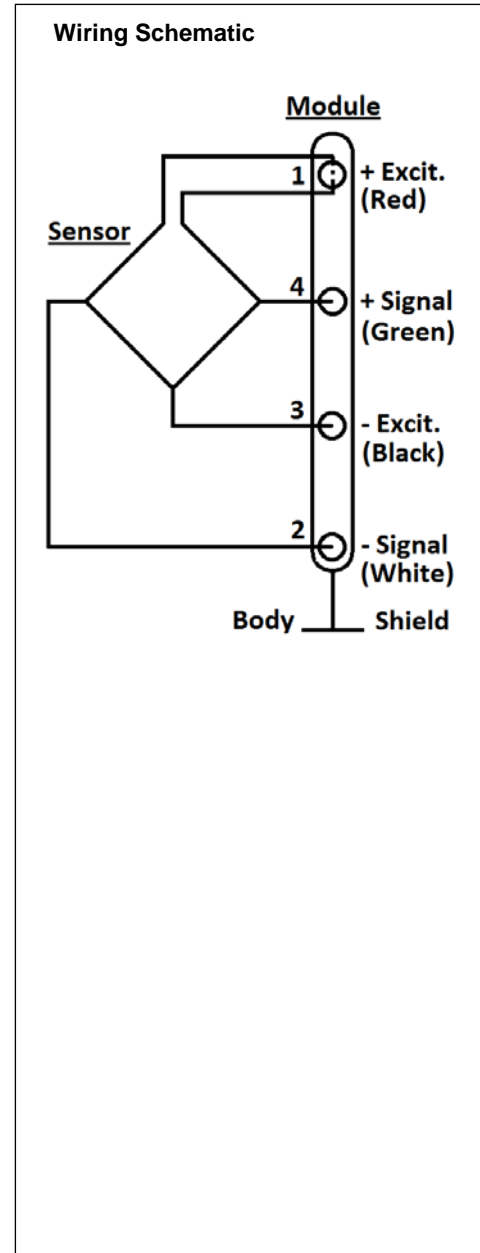
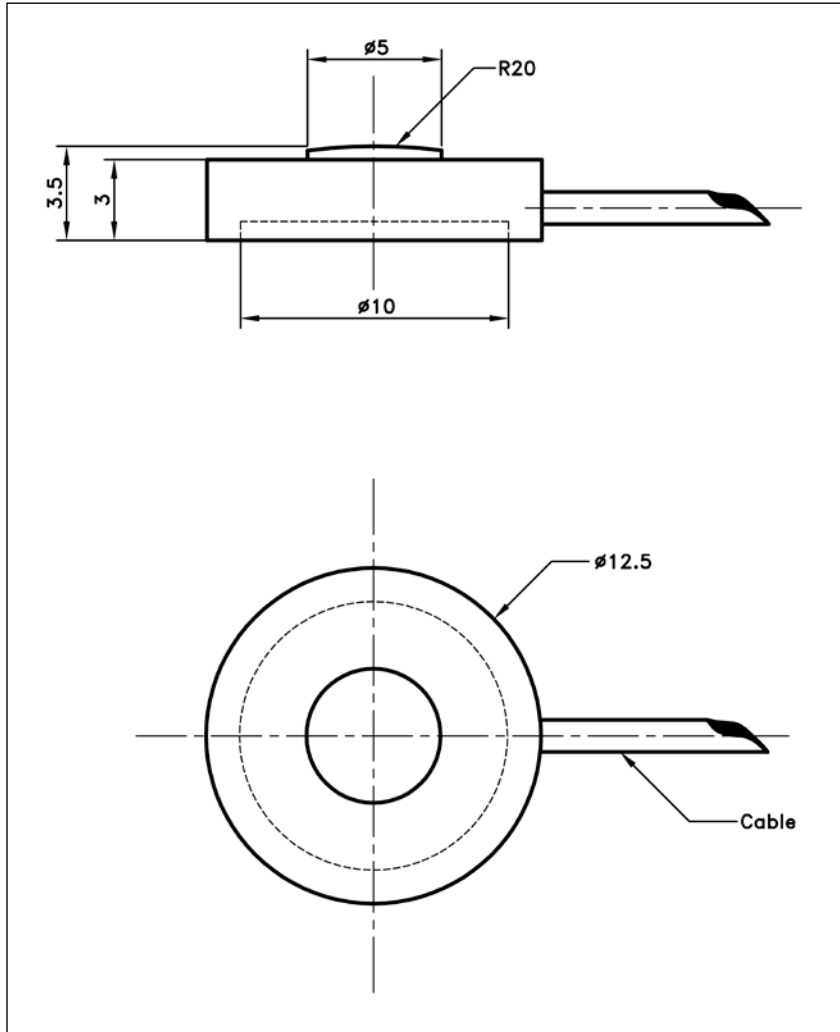

Dimensions in mm [inch]

|                               |   |  |
|-------------------------------|---|--|
| F. S. Ranges In N<br>[in lbf] | 5 - 10 - 20 - 50 - 100<br>[1 - 2 - 4 - 10 - 20] | 200 - 500<br>[40 - 100]                |
| Material                      | Aluminum  | Stainless steel                        |
| Stiffness in N/m              | $1.3 \times 10^5$ to $1.2 \times 10^8$          | $1.9 \times 10^8$ to $7.6 \times 10^8$ |
| Stiffness in lbf/ft           | $8.9 \times 10^4$ to $8.2 \times 10^5$          | $1.3 \times 10^7$ to $5.2 \times 10^7$ |

# XFL212R Miniature Load Cell

## OPTIONS

|   |  |
|---|--|
| <b>ET1</b>  | : CTR -20 to 100° C [-4 to 212° F]                               |
| <b>ET2</b>  | : CTR -40 to 120° C [-40 to 248° F]                              |
| <b>ET3</b>  | : CTR -40 to 150° C [-40 to 302° F] OTR=CTR                      |
| <b>L00M</b>   | : special cable length, replace "00" with total length in meters |
| * Order Flat Force application surface with reference <b>XFL212</b> . |  |

## ORDERING INFO

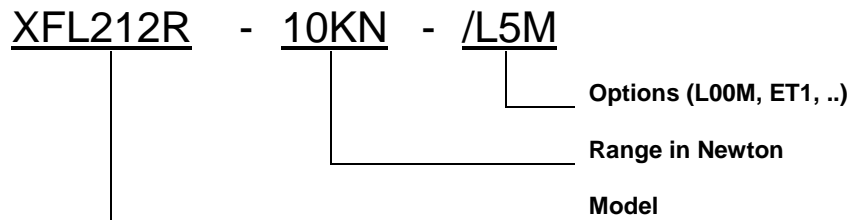

### NORTH AMERICA

Measurement Specialties, Inc.  
 Vibration Design Center  
 32 Journey - Suite 150  
 Aliso Viejo, CA 92656  
 United States USA  
 Tel: 1-949-716-0877  
 Fax: 1-949-916-5677  
[t&m@meas-spec.com](mailto:t&m@meas-spec.com)

### EUROPE

Measurement Specialties  
 (Europe), Ltd.  
 26 Rue des Dames  
 78340 Les Clayes-Sous-Bois,  
 France  
 Tel: +33 (0) 130 79 33 00  
 Fax: +33 (0) 134 81 03 59  
[cs.lcsb@meas-spec.com](mailto:cs.lcsb@meas-spec.com)

### ASIA

Measurement Specialties  
 (China), Ltd.  
 No. 26 Langshan Road  
 Shenzhen High-Tech Park (North)  
 Nanshan District, Shenzhen  
 518057  
 China  
 Tel: +86 755 3330 5088  
 Fax: +86 755 3330 5099  
[pfg.cs.asia@meas-spec.com](mailto:pfg.cs.asia@meas-spec.com)

The information in this sheet has been carefully reviewed and is believed to be accurate; however, no responsibility is assumed for inaccuracies. Furthermore, this information does not convey to the purchaser of such devices any license under the patent rights to the manufacturer. Measurement Specialties, Inc. reserves the right to make changes without further notice to any product herein. Measurement Specialties, Inc. makes no warranty, representation or guarantee regarding the suitability of its product for any particular purpose, nor does Measurement Specialties, Inc. assume any liability arising out of the application or use of any product or circuit and specifically disclaims any and all liability, including without limitation consequential or incidental damages. Typical parameters can and do vary in different applications. All operating parameters must be validated for each customer application by customer's technical experts. Measurement Specialties, Inc. does not convey any license under its patent rights nor the rights of others.