

CS1120 Reaction Torque Sensor



- Keyed Shaft Mechanical Connection
- Range from ± 5 to $\pm 2,500$ Nm (± 4 to $\pm 2,000$ lbf.ft)
- Stainless Steel
- Cable Gland or Connector Output
- Built In Amplifier per Request

DESCRIPTION

The **CS1120** Series has been designed to measure torque from in static applications. Fitted with metallic strain gauges in a Wheatstone bridge circuit, the **CS1120** is providing excellent temperature stability. For high-level output a model with integrated amplifier is available.

With many years of experience as a designer and manufacturer of sensors, Measurement Specialties, Inc. often works with customers to design or customize sensors for specific uses and testing environments.

To meet your needs we also offer complete turnkey systems. The matched components (sensor, power, amplifier and digital display) are formatted, calibrated and ready for immediate use.

FEATURES

- For Static Applications
- Keyed Shaft Mechanical Connection
- High Level Output Model with Integrated Amplifier

APPLICATIONS

- Process control equipment
- Torque calibration benches
- Robotics and effectors
- Laboratory and Research

STANDARD RANGES

F.S range in Nm	5 to 20	21 to 100	101 to 300	301 to 800	801 to 2.5k
F.S range in lbf.ft	4 to 16	17 to 80	81 to 240	241 to 640	641 to 2k
Stiffness in Nm/rad	2×10^2 to 1.2×10^3	1.2×10^3 to 1×10^4	1×10^4 to 4.1×10^4	4.1×10^4 to 1.2×10^5	1.2×10^5 to 6×10^5
Stiffness in lbf.ft/rad	0.1×10^2 to 0.8×10^2	0.8×10^2 to 6.9×10^2	6.9×10^2 to 2.7×10^3	2.7×10^3 to 8.2×10^3	8.2×10^3 to 4.1×10^4

CS1120 Reaction Torque Sensor

PERFORMANCE SPECIFICATIONS

All values are typical at temperature 20±1° C

Parameters	
Operating Temperature Range (OTR)	-20 to 80° C (-4 to 176° F)
Compensated Temperature Range (CTR)	0 to 60° C (32 to 140° F)
Zero Shift in CTR	<0.5% F.S./ 50°C [1/100° F]
Sensitivity Shift in CTR	<1% of reading / 50° C [1/100° F]
Range (F.S.)	±5 Nm to ±2.5kNm [±4 lbf.ft to ±2 klbf.ft]
Over-Range	
Without Damage	1.5 x F.S.
Accuracy	
Combined Non-Linearity & Hysteresis	±0.25% F.S.

Electrical Characteristics

Model	CS1120	CS1120-A1	CS1120-A2
Supply Voltage	10Vdc	10 – 30Vdc	±15Vdc (±12 to ±18Vdc)
F.S. Output ⁴	±2mV/V	±2V ±5%	±5V ±5%
Zero Offset ⁴	<±5% F.S.	2.5V ±5% F.S.	0V ±5% F.S.
Input Impedance/Consumption	350 to 700Ω	<30mA	<30mA
Output Impedance	350 to 700Ω	1 kΩ ⁵	1 kΩ ⁵
Insulation under 50Vdc	≥100MΩ	≥100MΩ	≥100MΩ

Notes

1. Electrical Termination: Connector output including mate
2. Material: Body in stainless steel ; housing in aluminum alloy
3. Connection : Keyed shaft standard, other connection types on request (smooth shaft, cotter pin, etc)
4. Other signal output on request
5. Output impedance < 100Ω on request
6. CE conformance according to EN 61010-1, EN 50081-1, EN 50082-1

CS1120 Reaction Torque Sensor

DIMENSIONS & WIRING SCHEMATIC (IN METRIC AND IMPERIAL)

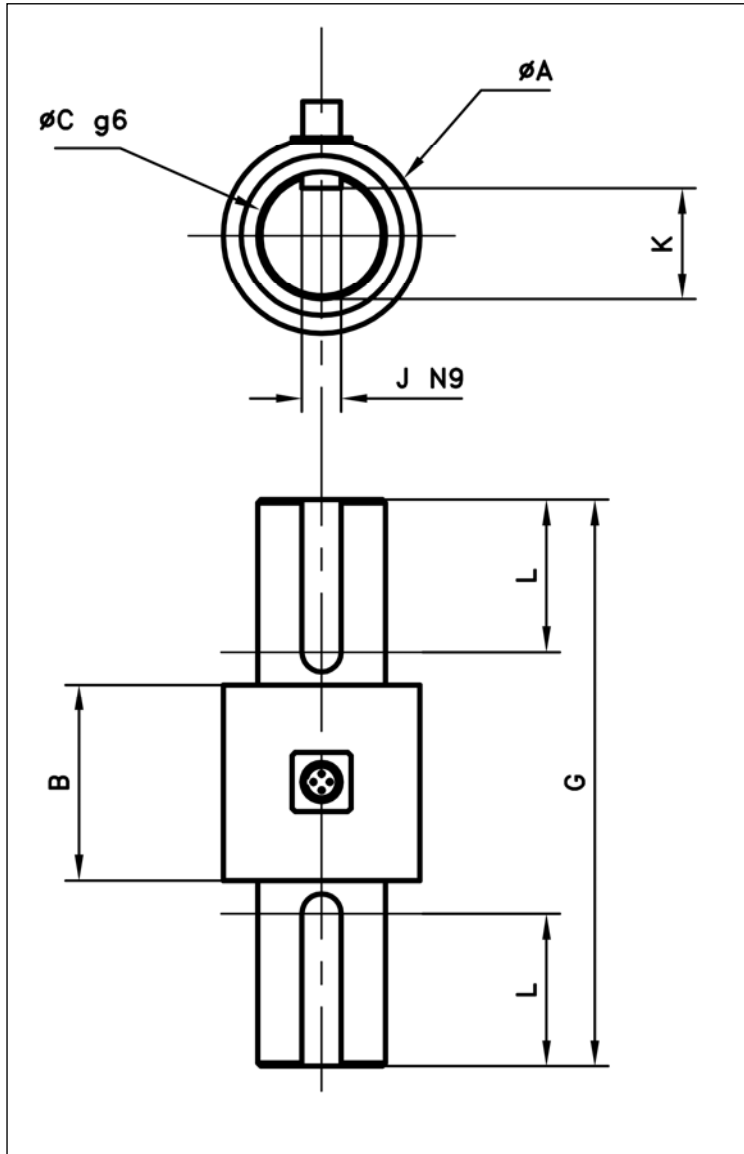

Wiring Schematic

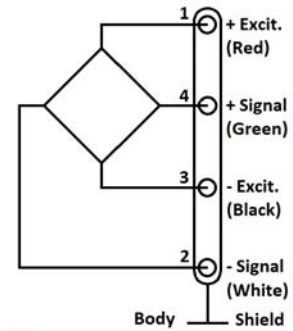

Version -A1

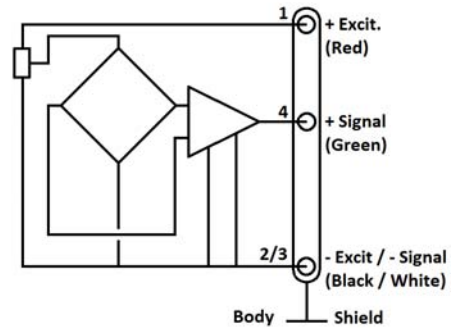

Version -A2

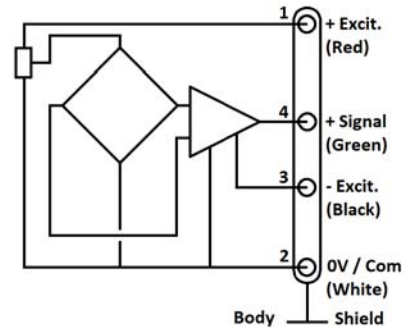

Dimensions in mm [inch]

F.S. in N.m [lbf.ft]	5 to 20 [4 to 16]		21 to 100 [17 to 80]		101 to 300 [81 to 240]		301 to 800 [241 to 640]		801 to 2,5k [641 to 2k]	
A	35	[1.38]	35	[1.38]	40	[1.57]	50	[1.97]	65	[2.56]
B	35	[1.38]	35	[1.38]	40	[1.57]	45	[1.77]	55	[2.17]
C	14	[0.55]	19	[0.75]	28	[1.10]	39	[1.54]	54	[2.13]
G	75	[2.95]	95	[3.74]	135	[5.31]	165	[6.50]	240	[9.45]
J	5	[0.20]	6	[0.24]	8	[0.31]	12	[0.47]	16	[0.63]
K	11	[0.43]	15.5	[0.61]	24	[0.94]	34	[1.34]	48	[1.89]
L	15	[0.59]	25	[0.98]	40	[1.57]	50	[1.97]	80	[3.15]

CS1120 Reaction Torque Sensor

OPTIONS

A1 : Amplified Tension output with unipolar power supply
A2 : Amplified Tension output with bipolar power supply
FMC : Mating connector fitting with 2 m [6.6 ft] cable

ORDERING INFO

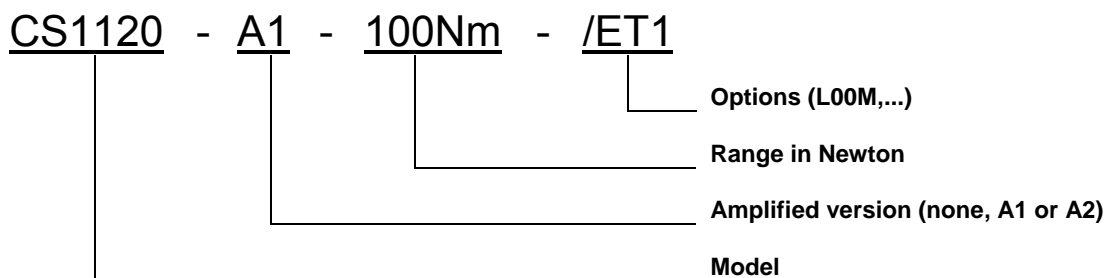

NORTH AMERICA

Measurement Specialties, Inc.
Vibration Design Center
32 Journey - Suite 150
Aliso Viejo, CA 92656
United States USA
Tel: 1-949-716-0877
Fax: 1-949-916-5677
t&m@meas-spec.com

EUROPE

Measurement Specialties
(Europe), Ltd.
26 Rue des Dames
78340 Les Clayes-Sous-Bois,
France
Tel: +33 (0) 130 79 33 00
Fax: +33 (0) 134 81 03 59
cs.lcsb@meas-spec.com

ASIA

Measurement Specialties
(China), Ltd.
No. 26 Langshan Road
Shenzhen High-Tech Park (North)
Nanshan District, Shenzhen
518057
China
Tel: +86 755 3330 5088
Fax: +86 755 3330 5099
pfg.cs.asia@meas-spec.com

The information in this sheet has been carefully reviewed and is believed to be accurate; however, no responsibility is assumed for inaccuracies. Furthermore, this information does not convey to the purchaser of such devices any license under the patent rights to the manufacturer. Measurement Specialties, Inc. reserves the right to make changes without further notice to any product herein. Measurement Specialties, Inc. makes no warranty, representation or guarantee regarding the suitability of its product for any particular purpose, nor does Measurement Specialties, Inc. assume any liability arising out of the application or use of any product or circuit and specifically disclaims any and all liability, including without limitation consequential or incidental damages. Typical parameters can and do vary in different applications. All operating parameters must be validated for each customer application by customer's technical experts. Measurement Specialties, Inc. does not convey any license under its patent rights nor the rights of others.