

FN3050 Load Cell Tension and Compression

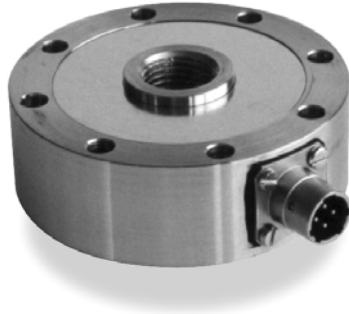

- Pancake load cell
- Range from 100 to 20000 N (20 to 4000 lbf)
- Accuracy: 0.1% F.S.
- Stainless steel or aluminum
- Connector or cable gland output
- Build in amplifier per request



DESCRIPTION

The rugged **FN3050** load cell is highly suited for process industry and test bench applications. Dimensions are identical in standard ranges from 0-100 to 0-20000 N so during testing the sensor can be interchanged for another of a different range without mechanical modifications. The sensor design minimizes transverse effects. For high-level output a model with integrated amplifier is available as are numerous other options.

With many years of experience as a designer and manufacturer of sensors, Measurement Specialties, Inc. often works with customers to design or customize sensors for specific uses and testing environments.

To meet your needs we also offer complete turnkey systems. The matched components (sensor, power, amplifier and digital display) are formatted, calibrated and ready for immediate use.

FEATURES

- Same housing for all ranges
- Tension and compression
- Mechanical stops in option
- Optional : Tension Pull Plate, Load Button
- Accuracy : 0.1% F.S.

APPLICATIONS

- Process control equipment
- Regulation load cell
- Robotics and effectors
- Laboratory and Research
- Dedicated to low and medium quantity volume

STANDARD RANGES

Ranges in N	100	200	500	1k	2k	5k	10k	20k
Ranges in lbf	20	40	100	200	400	1k	2k	4k
Stiffness in N/m	1x10 ⁶	2.5x10 ⁶	1x10 ⁷	1.7x10 ⁷	5x10 ⁷	1.2x10 ⁸	2x10 ⁸	4x10 ⁸
Stiffness in lbf/ft	6.9x10 ⁴	1.7x10 ⁵	6.9x10 ⁵	1.2x10 ⁶	3.4x10 ⁶	8.2x10 ⁶	1.4x10 ⁷	2.7x10 ⁷
Material	Aluminium			Stainless Steel		Aluminium	Stainless Steel	

FN3050 Load Cell Tension and Compression

PERFORMANCE SPECIFICATIONS

All values are typical at temperature 20±1° C

PARAMETERS	
Operating Temperature Range (OTR)	-20 to 80° C [-4 to 176° F]
Compensated Temperature Range (CTR)	0 to 60° C [32 to 140° F]
Zero Shift in CTR	<0.5% F.S. / 50° C [/100° F]
Sensitivity Shift in CTR	<1 % of reading / 50° C [/100° F]
Range (F.S.)	0-10 to 0-1000 kN [0-2 to 0-200 klb]
Over-Range	
Without Damage	1.5 x F.S. (10 x F.S. with optional mechanical stops)
Without Destruction	3 x F.S.

Accuracy								
Ranges in N	100	200	500	1k	2k	5k	10k	20k
Ranges in lbf	20	40	100	200	400	1k	2k	4k
Linearity (%F.S.)	-	-	0.1	0.1	0.1	0.1	0.1	0.1
Hysteresis (%F.S.)	-	-	0.1	0.1	0.1	0.1	0.1	0.1
Combined linearity & hysteresis (%FS)	0.3	0.3	-	-	-	-	-	-

Electrical Characteristics

Model	FN3050	FN3050-A1	FN3050-A2
Supply Voltage	10Vdc	10 – 30Vdc	±15Vdc (±12 to ±18Vdc)
F.S. Output ⁴	±1.5mV/V	±2V ±5% F.S.	±5V ±5% F.S.
Zero Offset ⁴	±5% F.S.	2.5V ±5% F.S.	0V ±5% F.S.
Input Impedance/Consumption	350 to 700Ω	<50mA	50mA
Output Impedance	350 to 700Ω	1 kΩ ⁵	1 kΩ ⁵
Insulation under 50Vdc	≥100MΩ	≥100MΩ	≥100MΩ

Notes

1. Electrical Termination: Connector output including mate
2. Body in stainless steel or aluminium alloy depending on F.S.
4. Other signal output on request
5. Output impedance < 100Ω on request
6. CE conformance according to EN 61010-1, EN 50081-1, EN 50082-1

FN3050 Load Cell Tension and Compression

DIMENSIONS & WIRING SCHEMATIC (IN METRIC AND IMPERIAL)

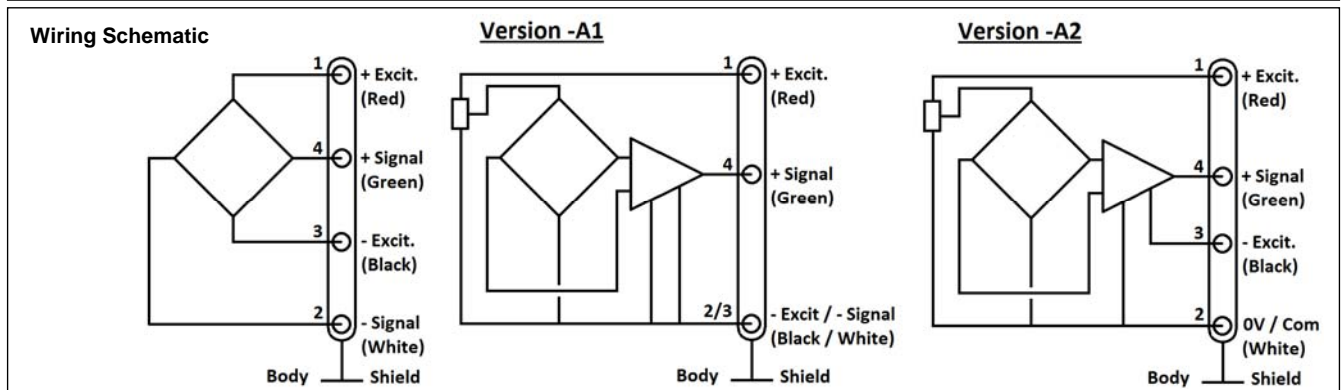
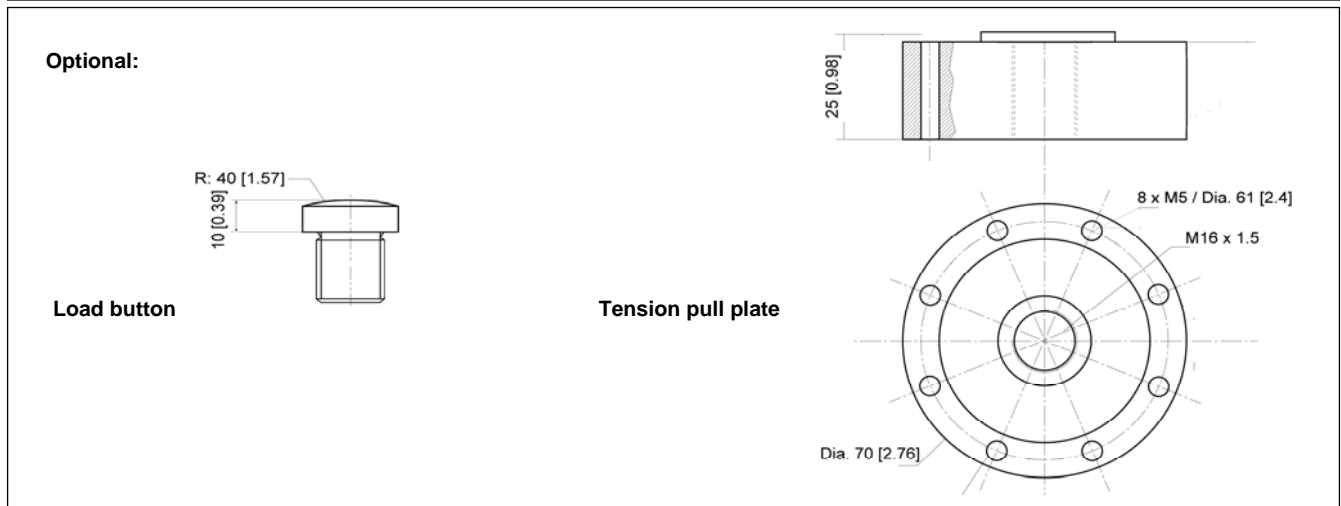
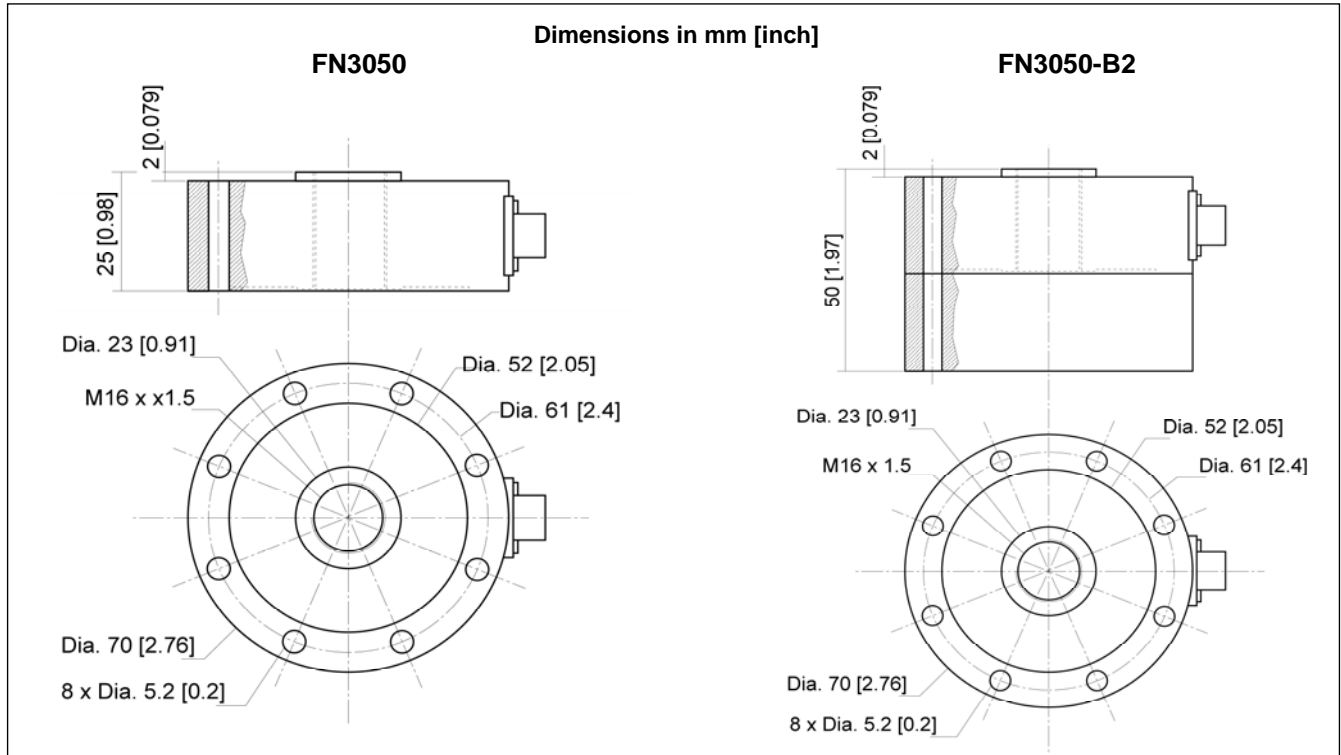

FN3050 Load Cell Tension and Compression

OPTIONS

A1 : Amplified Tension output with unipolar power supply
A2 : Amplified Tension output with bipolar power supply
ET1 : CTR -20 to 100° C [-4 to 212° F] OTR = CTR
ET2 : CTR -40 to 120° C [-40 to 248° F] OTR = CTR
ET3 : CTR -40 to 150° C [-40 to 302° F] OTR = CTR (Note : ET3 not available with A1 and A2 options)
B2 : Mechanical stops (compression only, models ≤2000 N; [≤400 lbf])
PE : Cable Gland Termination with 2 m [6.5 ft] cable
PE/L00M : Additional cable length with PE option, replace "00" with total length in meters

ORDERING INFO

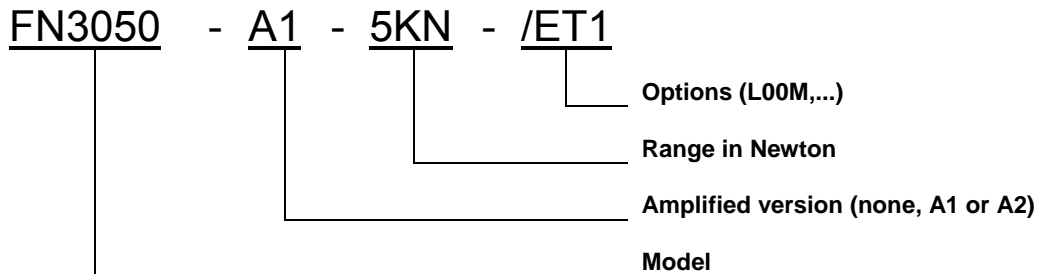

RECOMMENDED ACCESSORIES

EH : Hemispherical load button
FF : Tension pull plate

NORTH AMERICA

Measurement Specialties, Inc.
Vibration Design Center
32 Journey - Suite 150
Aliso Viejo, CA 92656
United States USA
Tel: 1-949-716-0877
Fax: 1-949-916-5677
t&m@meas-spec.com

EUROPE

Measurement Specialties
(Europe), Ltd.
26 Rue des Dames
78340 Les Clayes-Sous-Bois,
France
Tel: +33 (0) 130 79 33 00
Fax: +33 (0) 134 81 03 59
cs.lcsb@meas-spec.com

ASIA

Measurement Specialties
(China), Ltd.
No. 26 Langshan Road
Shenzhen High-Tech Park (North)
Nanshan District, Shenzhen
518057
China
Tel: +86 755 3330 5088
Fax: +86 755 3330 5099
pfg.cs.asia@meas-spec.com

The information in this sheet has been carefully reviewed and is believed to be accurate; however, no responsibility is assumed for inaccuracies. Furthermore, this information does not convey to the purchaser of such devices any license under the patent rights to the manufacturer. Measurement Specialties, Inc. reserves the right to make changes without further notice to any product herein. Measurement Specialties, Inc. makes no warranty, representation or guarantee regarding the suitability of its product for any particular purpose, nor does Measurement Specialties, Inc. assume any liability arising out of the application or use of any product or circuit and specifically disclaims any and all liability, including without limitation consequential or incidental damages. Typical parameters can and do vary in different applications. All operating parameters must be validated for each customer application by customer's technical experts. Measurement Specialties, Inc. does not convey any license under its patent rights nor the rights of others.