

318A Cable Assembly

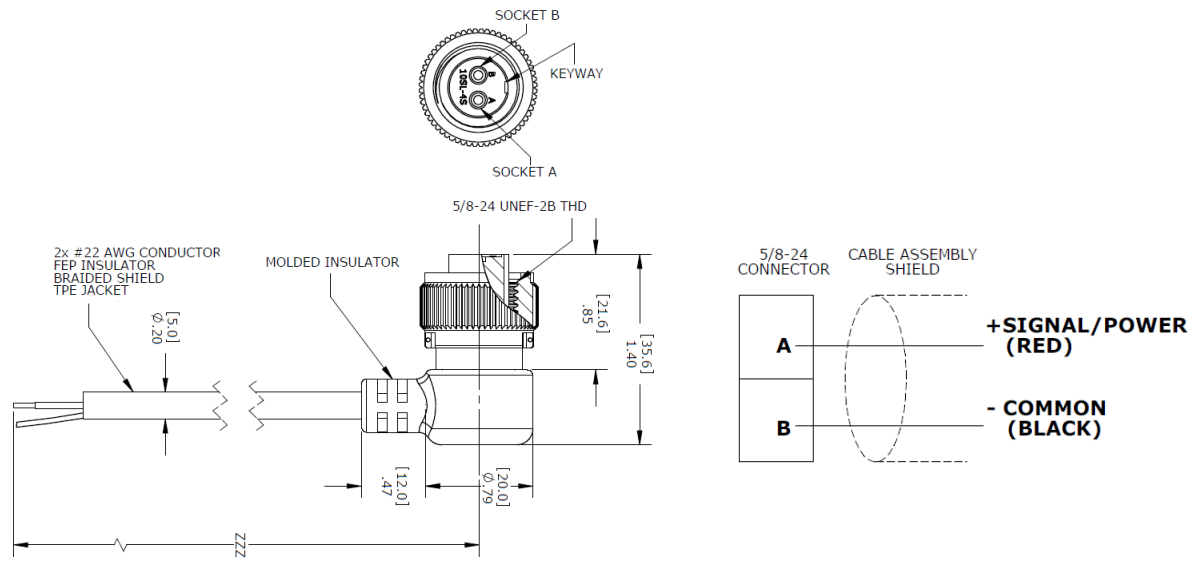

DIMENSIONS



DESCRIPTION

Industrial cable for the 8011 and 8021 condition monitoring accelerometers. The 318A cable includes a 2-pin connector with molded 90° backshell to pigtail leads. It features 2x #22 AWG FEP insulated conductors, braided shield and a flexible TPE jacket. Cables come in standard lengths of 10ft, 20ft, 30ft, and 50ft. Contact factory for custom cable lengths.

FEATURES

- TPE Jacket
- FEP Insulated #22 AWG Conductors
- TPC Braided Shield
- Molded 90° Backshell
- 50°C to +125°C Temp Range

APPLICATIONS

- Industrial Applications
- Machine Monitoring
- General Purpose
- Gearbox Monitoring

ORDERING CODE

318A-ZZZ (-ZZZ designates length in inches)

NORTH AMERICA

Measurement Specialties, Inc.

1000 Lucas Way
Hampton, VA 23666
USA

Sales and Customer Service

Tel: +1-800-745-8008 or

+1-757-766-1500

Fax: +1-757-766-4297

t&m@meas-spec.com

EUROPE

**Measurement Specialties
(Europe) Ltd.**

26 Rue des Dames
F78340 Les Clayes-sous-Bois
France

Sales and Customer Service

Tel: +33 (0) 1 79 33 00

Fax: +33(0)1 34 81 03 59

t&m@meas-spec.com

ASIA

**Measurement Specialties
(China), Ltd.**

No. 26 Langshan Road
Shenzhen High-Tech Park (North)
Nanshan District
Shenzhen, China 518057

Sales and Customer Service

Tel: +86 755 3330 5088

Fax: +86 755 3330 5099

t&m@meas-spec.com

The information in this sheet has been carefully reviewed and is believed to be accurate; however, no responsibility is assumed for inaccuracies. Furthermore, this information does not convey to the purchaser of such devices any license under the patent rights to the manufacturer. Measurement Specialties, Inc. reserves the right to make changes without further notice to any product herein. Measurement Specialties, Inc. makes no warranty, representation or guarantee regarding the suitability of its product for any particular purpose, nor does Measurement Specialties, Inc. assume any liability arising out of the application or use of any product or circuit and specifically disclaims any and all liability, including without limitation consequential or incidental damages. Typical parameters can and do vary in different applications. All operating parameters must be validated for each customer application by customer's technical experts. Measurement Specialties, Inc. does not convey any license under its patent rights nor the rights of others.